



“H” Lip Seal Maintenance & Repair Instructions

When H408 SEALS are replaced, the following procedure should be followed: (see figs below)

- a) Place GLAND NUT H406 and GLAND WASHER H409 on PISTON ASSEMBLY H423.
- b) First insert the LIP SEAL INSTALLATION TOOL on Piston. (See chart for part number)
- c) Form Lip of LIP SEAL around TOOL by gently placing one LIP SEAL, **Lip Side last**, on to TOOL, while carefully rotating the SEAL to avoid damage to the Lip. Then Remove seal from TOOL, reverse Lip Seal direction and reinstall seal, **Lip side first**, on to piston.
- d) Gently place the next two LIP SEALS H408, one at a time, on the TOOL, **Lip Side Last**; while carefully rotating the Seals on the TOOL to avoid damage to the Lip.
- e) Slide the TOOL off of the Piston Assembly.
- f) Insert Piston with seals into CYLINDER Assembly H422 and tighten GLAND NUT H406 to a torque of $22 \pm 10\%$ inch Lbs. ($2.49 \text{ N}\cdot\text{m} \pm 10\%$)

ROTATE PISTON BY HAND AFTER REASSEMBLY TO ASSURE FREE MOVEMENT IN CYLINDER.

****CAUTION NEVER WITHDRAW THE PISTON MORE THAN 3/4”(19 mm) OTHERWISE SEALS COULD BE DAMAGED BY FLAT OF THE PISTON. ****

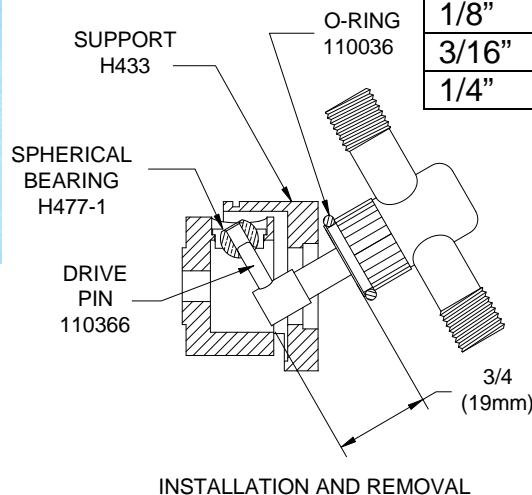
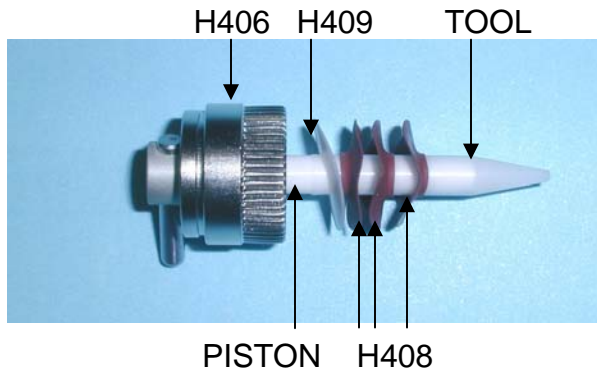

PISTON SIZE	INSTALLATION TOOL
1/8"	500074
3/16"	500072
1/4"	500071

YOUR EXACT SEAL CONFIGURATION MAY VARY, BUT THE PROCEDURE IS THE SAME.