



# IVSP Industrial Variable Speed Pump

## Quick Start Instructions

FOR ADDITIONAL REFERENCES SEE MANUALS FM50, H431, & Q431

### SAFETY INSTRUCTIONS



Before using any Fluid Metering, Inc. product read the following safety instructions as well as specific product specifications and operating instructions.



**Warning!** Fire, electrical shock or explosion may occur if used near combustibles explosive atmosphere, corrosive air, wet environment or submerged in fluid.

- Turn off the electrical power before checking pump for any problems.
- Connect motor, speed controllers, or any other electrical devices based on Fluid Metering Inc. specifications. Any unauthorized work performed on the product by the purchaser or by third parties can impair product functionality and thereby relieves Fluid Metering, Inc. of all warranty claims or liability for any misuse that will cause damage to product and/or injury to the individual.
- Power cables and leads should not be bent, pulled or inserted by excessive force. Otherwise there is a threat of electrical shock or fire.
- Replace any inline fuses only with fuse rating as specified by Fluid Metering, Inc.
- When pump/drive is under operation, never point discharge tubing into face or touch any rotating components of pump.  
In a power down thermal overload cut-in condition, unplug or turn off power to pump. Always allow a cool down period before restarting: otherwise, injury or damage may occur.
- For 30 seconds after power is removed from pump/drive: do not touch any output terminals. Electrical shock may occur because of residual voltage.



**Caution!** Fire, electrical shock, injury and damage may occur if not used in accordance with Fluid Metering, Inc. specifications and operation instructions.

- Do not put wet fingers into power outlet of unit.
- Do not operate with wet hands.
- Do not operate drive assemblies that require a hard mount (to be bolted down) unless they are mounted per Fluid Metering, Inc. specifications, if not injury may occur and/or damage to unit.
- Do not touch any rotating pump or motor components: injury may occur.
- Do not run pump dry, unless designed for that service. Running dry is harmful to the pump, and will cause excessive heating due to internal friction.
- Check pump rotation and inlet/outlet pump port orientation before connecting power to pump. If not injury may occur.
- When pulling out cords from outlets do not pull cord, grasp plug to prevent plug damage or electrical shock.
- Fluid Metering, Inc. Drive Motors become HOT and can cause a burn. **DO NOT TOUCH!**



### Overview

The IVSP Industrial Variable Speed Pump system consists of a 3 phase, high torque, variable speed pump and FM50 variable speed controller.

The FM50 controller is powered by 115 VAC 1 phase and provides 230 VAC 3 phase to power & control the drive motor. Line cord cable to the FM50 and connection cable between the FM50 and motor is supplied.



### Features

- FMI's Patented CeramPump® valveless piston pump design
- Rugged, 1/4 HP 3 phase high torque motor ideal for metering viscous fluids
- Space-saving DIN mount controller for installation in process control panels
- Convenient front panel membrane switches with 3 Digit LED to facilitate programming
- Selectable Manual or Analog input (0-10V, 4-20 mA, 0-20 mA) for communication with process instrumentation
- All electronic components  



**FLUID METERING, INC.**

5 Aerial Way, Suite. 500, Syosset, New York 11791  
516-922-6050 • pumps@fmpump.com • www.fmpump.com



**Note:** Prior to applying power to the controller carefully read all warnings and safety precautions in the *Flux Master FM50 Instruction Manual & User Manual*. Failure to adhere to the warning and safety precautions could result in injury and damage to property. **IMPORTANT: DO NOT EXCEED SPEED OF 60 HZ.**

**Note:** The FM50 comes with factory default settings. Care should be taken when changing these values. To restore the drive to the original factory default values see “**Restore Factory Default Settings**” in this document.

## **Quick Start (Initial operation “out of the box”)**

### **Initial Use:**

1. Connect cable from motor to controller per FMI outline drawing 600173.
2. Connect AC cord to controller per FMI outline drawing 600173.
3. Plug line cord to 115 VAC 50/60 Hz source.
4. Controller will display 5.0 (150 RPM).

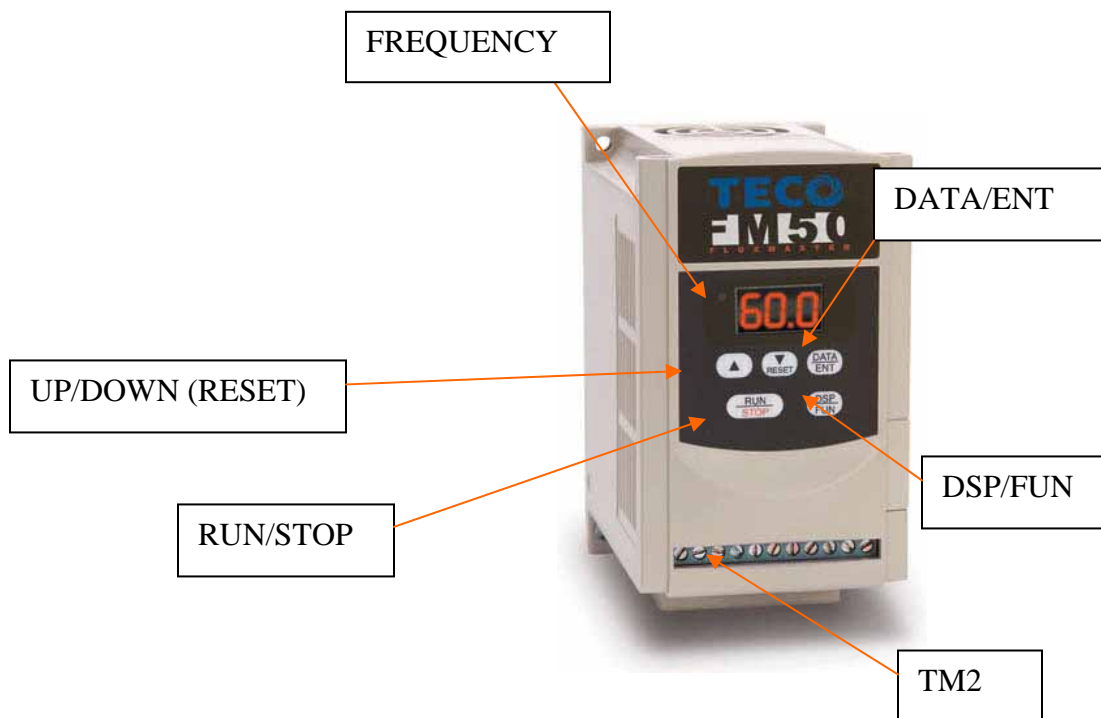

5. Command a RUN by pressing the RUN/STOP button. Motor will spin CW to 150 RPM.
6. Pushing the UP/DOWN buttons will increase/decrease the speed accordingly.
7. Factory default maximum frequency is 60 Hz (1800 RPM). *Care should be taken not allow the maximum frequency to exceed 60 Hz (1800 RPM).*

### **Foot Switch Operation (Run/Stop mode):**

To use the controller with a standard “dry contact” switch to control Start/Stop and direction the following settings should be made.

1. Set F\_10 to 1 \*\*\*
2. Connect pin 3 to Pin 5 of TM2. Motor will start to accelerate until set frequency is reached.
3. Direction can be controlled by via TM2 pin 4 to TM2 pin 5.
  - a. TM2 pin 4 open spins motor in the Forward direction
  - b. TM2 pin 4 connected to TMP2 pin 5 TM2 pin 4 open spins motor in the Reverse direction

### **Analog Frequency (Speed) Command:**

To control the frequency (speed) of the motor via 0 – 10 VDC, 0 – 20 mA or 4 – 20 mA the following settings should be made.

1. Control type setting (F\_11) \*\*\*
  - a. For 0 – 10 VDC / 0 – 20 mA input set F\_11 to 1
  - b. For 4 – 20 mA set F\_11 to 2
2. Input control signal into TM2 pin 9
  - a. For FM\_11 = 1 use 0 – 10 VDC or 0 – 20 mA
  - b. For FM11 = 2 use 4 – 20 mA
3. Command Start via Keypad

### **Restore Factory Default Settings:**

To return the drive to a factory default, perform the following steps.

1. Restore factor fault (F\_25) \*\*\*
  - a. For 50 Hz system set F\_25 to 10
  - b. For 60 Hz system set F\_25 to 20

### **\*\*\* To Change Function (F ) value:**

Press  to get to desired function

Press  to select desired function value

Press  to select function

Press  to select function value

Press  to accept value

# IVSP1 SPECIFICATIONS

## PUMP DRIVE MODULE

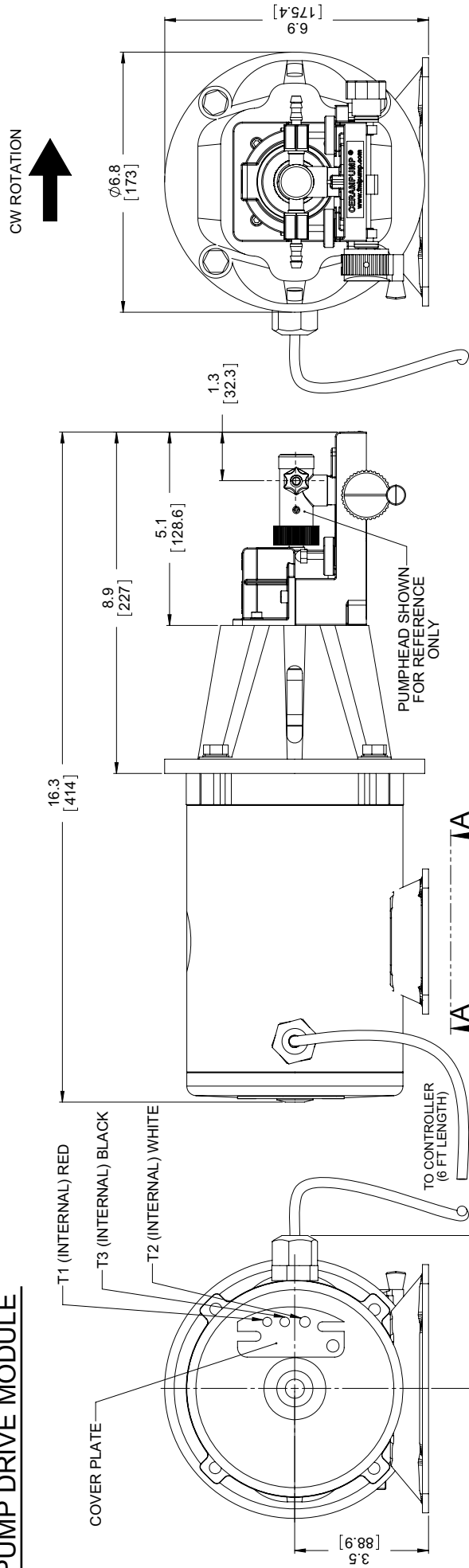

## CONTROLLER

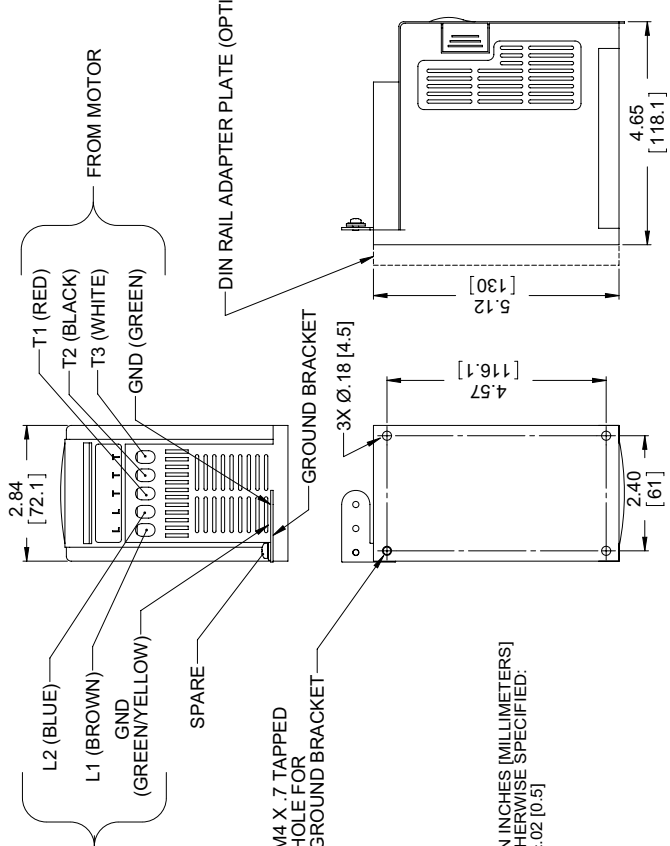

## VIEW A-A MOTOR MOUNT

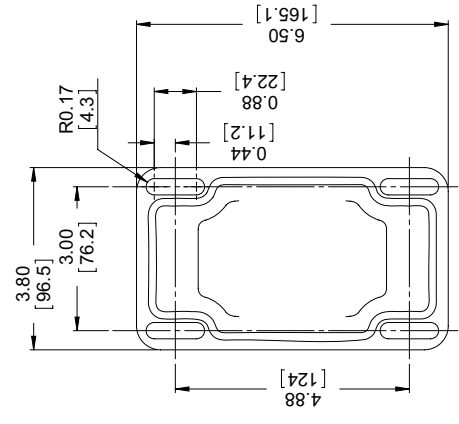

SPECIFICATIONS:  
 MIN SPEED 60 RPM @ 2HZ  
 MAX SPEED : 1800 RPM @ 60HZ  
 INPUT : 115VAC, 50/60 HZ

FMI P/N IVSP1

<b>FLUID METERING, INC.</b> <small>5 Aerial Way, Suite 500 Syosset, N.Y. 11791</small>		
TITLE		
IVSP1 OUTLINE		
DWG NO	REV	SHT 1 OF 1
600173	B	

NOTE: DIMENSIONS ARE IN INCHES (MILLIMETERS)  
 TOLERANCES UNLESS OTHERWISE SPECIFIED:  
 .X = ±.06 [1.5] .XX = ±.02 [0.5]